

UNLOCK THE POWER OF BOUNDARY-SCAN

*PCB Test & Programming Solutions
from the IEEE 1149.1 Boundary-Scan Experts*



JTAG
Technologies B.V.

Solutions

for Today's Test and Programming Problems

Throughout the electronics industry, manufacturers are turning to the latest device technologies, such as ball-grid arrays, chip-scale packages, and other small outlines, to provide the functionality and miniaturization they need. However, along with the benefits, the new packages are increasing the difficulty of accessing printed circuit boards for testing and on-board device programming.

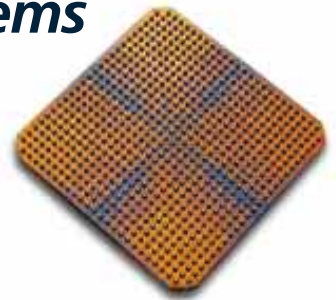

CPLD in BGA Package

Boards are becoming much more crowded, component complexity is increasing, and circuit performance issues are becoming more demanding. These difficult access problems have been addressed by the industry through adoption of the IEEE 1149.1 boundary-scan standard, allowing pin-level access— independent of the device packaging technology—to even the most crowded assemblies.

Now, the power of boundary-scan is yours, with advanced products from JTAG Technologies in compliance with the IEEE standard. You'll achieve practical solutions that you can implement today, realizing immediate and significant benefits. Moreover, the JTAG Technologies solutions apply uniformly throughout your business, with a common thread from development, through prototyping, production, and field service.

Company Background

JTAG Technologies B.V. is the world's foremost provider of comprehensive test and in-system programming solutions based on the IEEE Boundary-Scan standard 1149.1. We continuously enhance the value of the applications of this powerful standard with product improvements and innovations, based on the needs of our customers. Since our founding in 1993, we've applied our experience in the development of professional industrial instrumentation resulting in powerful development packages, production packages, and boundary-scan controller hardware.

We maintain a highly experienced staff of Development Engineers and Application Engineers ready to support your needs. With over 1,200 of our systems in operation around the world, our engineers have proven themselves in hundreds of real-world cases, providing everything from introductory training on up to the preparation of specific tests and programs to meet exacting customer requirements.

Our corporate headquarters are in Eindhoven, The Netherlands, and we have offices in the United Kingdom and the United States. In addition, we're represented by a global network of authorized distributors and representatives throughout North America, Europe, Asia, the Middle East, and Australia.

Practical and Powerful— Boundary-Scan from JTAG Technologies

With the JTAG Technologies' family of software tools and hardware controllers, you can easily unlock the tremendous power of boundary-scan for your test and programming applications. You'll find it a simple matter to create your first test or programming application and to add new ones. Board and system tests, as well as in-system programming routines, will be ready before the first prototype comes down the line. As a result, you'll realize significant improvement in your product's time-to-market. The same streamlining applies to handling design changes and product updates.

What has raised boundary-scan to this level of real-world practicality? JTAG Technologies' development and production systems provide your developers and production personnel with the assistance they need, simplifying the tasks and allowing them to concentrate on their mission, not the intricacies of boundary-scan.

Tests, diagnostics, and programming files can be created as soon as you have a schematic and netlist, without waiting for the board layout or for a complicated bed-of-nails test fixture. Since all the resulting files are compatible between development and production, as soon as the tests are verified in development, your factory will be ready to go.



Furthermore, you have a complete selection of high-quality boundary-scan controllers, designed specifically for critical industrial applications. Your choice ranges from a PC parallel port controller to high-performance ISA, PCI, USB, and VXI implementations. All of the controllers are designed by JTAG Technologies, assuring you of complete software and hardware compatibility.

A Full Range of Development Packages

To simplify your selection process, we've assembled our test and in-system programming software into development and production packages. You choose the package that's right for your design or engineering environment and your application, optimizing your investment. Of course, should your needs change, you can add individual software modules at any time.

All of the software packages are available for:

- 16-bit oriented operating systems (DOS/Windows 3.1x)
- 32-bit systems such as Windows 95, Windows 98, Windows NT, and UNIX (SunOS, Solaris, and HP-UNIX) platforms

Choose from Four Test Development Packages

Basic Test Development Package



The Basic Test Development Package is an entry-level system, well suited for applications involving less-complex PCBs or for companies with a limited number of new designs. The Basic Package contains all of the functionality needed to create complete boundary-scan tests for execution on the production floor, at a price for the budget minded.

The Basic Package provides automatic generation of test patterns for the boundary-scan infrastructure on your board. Test preparation for interconnections and clusters is done interactively using the highly intuitive graphical user interface of PowerVIP. The PowerVIP module also performs syntax and semantic checking of device BSDL files. Test failures are reported for analysis in a net-oriented truth-table format that engineers prefer and with which they are familiar. Since test generation is based on a netlist of the design, your tests can be ready before the prototypes come back from manufacturing.

Standard Test Development Package



Building on the interactive generation of test vectors, the Standard Package allows you to automate the generation of test patterns for boundary-scan interconnections, including coverage for inverters, serial resistors, multiplexers, and buffers that reside between scan elements. The Standard Package also provides automatic generation of test patterns through or to board connectors. Your test preparation time is reduced significantly, and full 100% coverage of the scan interconnections is achieved.

The Standard Package is a good choice to improve a test strategy that, for example, includes functional testing for complex surface-mount designs. In these situations, use boundary-scan to pre-screen product for manufacturing faults, quickly weeding them out, and allow the functional test phase to focus on true functional faults. Leverage the power

of the Standard Test Package to quickly generate tests for manufacturing faults and diagnose them accurately, significantly reducing the burden on functional test preparation and fault analysis.

Boundary-scan also brings substantial benefits to users of in-circuit test systems, relieving them of constraints caused by the limitations of test fixtures. As board complexity increases, bed-of-nail access to BGAs and other types of packages becomes impractical or impossible. JTAG Technologies' Standard Test Development Package provides you with the next generation test solution, solving the access problems and requiring only a small number of test points.

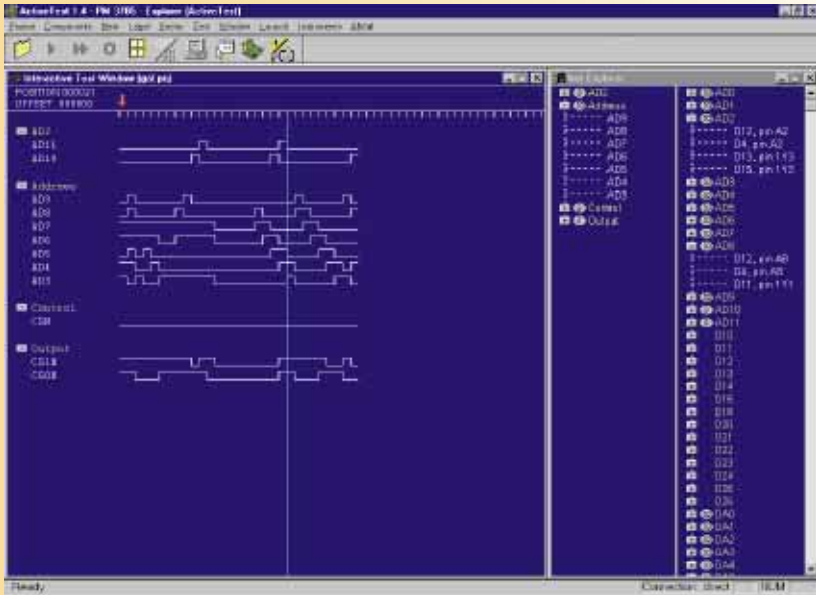

PowerVIP Graphical User Interface

problems occur in prototyping or later in production. If your company has adopted design-for-testability as an integral part of the design flow, you should consider the Professional Test Development Package.

Additional Valuable Products

The modularity of our architecture allows you to easily add other valuable options to any of the four test development packages:

- Advanced, intelligent diagnostics with pinpoint accuracy. This powerful fault identification tool is available with any of the Test Development Packages. Your engineers and production technicians will realize substantial benefit from the timesaving output reports.
- Linkage™ to your EDA schematic capture environment, an automated path between your schematic design system and the test and in-system flash programming application development modules. This option allows timely Design-for-Testability/Programmability prior to prototyping, and is available with any of the Test Development and Flash Development Packages.
- System-level testing and programming. All of our test and programming products provide system-level support using devices such as National Semiconductor's SCANBridge™ and Texas Instruments' Scan Path Linker.

Full Test Development Package



The Full Test Development Package is ideal for companies producing highly complex PCBs with SRAM,

DRAM and FIFO arrays, which desire the highest possible fault coverage and diagnostic resolution. This package contains all of our automatic vector generation tools including boundary-scan infrastructure, interconnections, memory interconnections, and the application of fault simulation vectors created on third-party tools for logic clusters. It enables you to move through test development rapidly, accommodating a large number of new designs at a consistently high quality level.

Professional Test Development Package



This package contains all of our automatic test pattern generators plus the Boundary-Scan Fault Coverage Examiner

(BFCE), empowering you to determine when all test requirements have been met. The combination of extensive pattern generation and coverage evaluation enables the R&D organization to operate at the highest quality level.

The Professional Package can be an integral part of your company's Total Quality Management program. You will have the ability to rapidly evaluate test effectiveness during PCB development, making adjustments on the spot, before

Test Development Packages	Windows GUI	BSDI Checking	Test Compilation	Test Execution	System-Level Support	Interactive Test Generation	ATPG for Infrastructure	Infrastructure Diagnostics	Truth-Table Report	ATPG for Interconnection	ATPG for Memory Interconnection	Test Pattern Import	Fault Coverage Calculation	Interface to EDA Tools	Pin-Level Diagnostics
Basic	✓	✓	✓	✓	✓	✓	✓	✓	✓					Opt.	Opt.
Standard	✓	✓	✓	✓	✓	✓	✓	✓	✓					Opt.	Opt.
Full	✓	✓	✓	✓	✓	✓	✓	✓	✓	✓	✓			Opt.	Opt.
Professional	✓	✓	✓	✓	✓	✓	✓	✓	✓	✓	✓	✓	Opt.	Opt.	

In-System Programming Development Packages

In-system programming of flash memories and PLDs (CPLDs and FPGAs) is quick and easy using JTAG Technologies' development tools. Your applications can include any combination of programmable devices from multiple vendors, because of the broad range of supported devices, all covered by a uniform toolset.

Standard Flash Development Package



Flash memories are the most rapidly growing segment of the programmable device market. Now with our Standard

Flash Development Package, you can configure flash devices on your board. The Standard Package provides you with a convenient graphical user interface to design your application and to script the modules you'll use later in production. If you have only a limited number of new designs, the Standard Package may be the solution for you.

Preparation of flash programming applications with the Standard Package is done by integrating information representing the board's netlist, descriptions of the boundary-scan devices, the characteristics of the flash memory, and the desired image data file.

Professional Flash Development Package



The Professional Package is ideal if you have several designs per year and need to respond rapidly to new

designs. With the Professional Package, your company maintains the flexibility to perform programming file generation as needed.

The Professional Package for flash features the industry's only advanced Boundary-Scan Flash Programming Generator (BFPG). With it, you'll quickly develop programming applications for new designs, using the extensive FlashLib library of the available devices, all generated automatically within our graphical user interface.

Standard PLD Development Package



The Standard PLD Development Package is best suited for companies using PLDs that support the new standardized

formats, or for those who use only a single family of logic devices. All PLD devices that use JAM or STAPL for programming files are supported by this package. Support options are also available to match any of the major CPLD families that use programming formats other than JAM or STAPL.

Full PLD Development Package

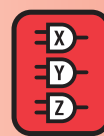

The Full PLD Development Package gives you support for all popular formats, including JEDEC, SVF, and TTF.

The benefit to you is avoiding proliferation of dedicated programmers, one for each of the vendors in your products, through the unified device support of the JTAG Technologies platform.

With this package you have the greatest possible flexibility to support a variety of PLD brands in your systems. This multi-vendor support is especially important in a manufacturing environment that is customarily confronted with multiple device sources and needs to avoid multiple tools.

Programming Development Packages	Windows GUI	BSDI Checking	ATPG for Infrastructure	Infrastructure Diagnostics	Compilation Flash/PLD	Execution Flash/PLD	AutoWrite Support	Scripting	Automatic Program Generation	Flash Library	Interface to EDA tools	JAM, STAPL Player	SVF, JEDEC, TTF	System-Level Support
Standard Flash	✓	✓	✓	✓	✓	✓	✓	✓						✓
Professional Flash	✓	✓	✓	✓	✓	✓	✓	✓	✓		Opt.			✓
Standard PLD	✓	✓	✓	✓	✓							✓	Opt.	Opt.
Full PLD	✓	✓	✓	✓	✓							✓	✓	Opt.

Boundary-Scan Technology

The IEEE 1149.1 standard defines a four-wire serial interface (a fifth wire is optional) to access complex integrated circuits (ICs) such as microprocessors, DSPs, ASICs, and CPLDs. Any compatible IC contains shift registers and a state machine to execute the boundary-scan functions. Data entering the chip on the **TDI** pin is stored in the instruction register or in one of the data registers. Serial data leaves the chip on the **TDO** pin. The boundary-scan logic is clocked by the signal on **TCK**, independent of the system clock. The **TMS** signal controls the state of the test access port (TAP). **TRST*** is optional and serves as a hardware reset signal.

Multiple scan-compatible ICs may be serially interconnected on the printed circuit board, forming the boundary-scan chain, and a board may contain more than one scan chain. The scan chain provides electrical access, from the serial TAP interface, to every pin on every IC that is part of the chain.

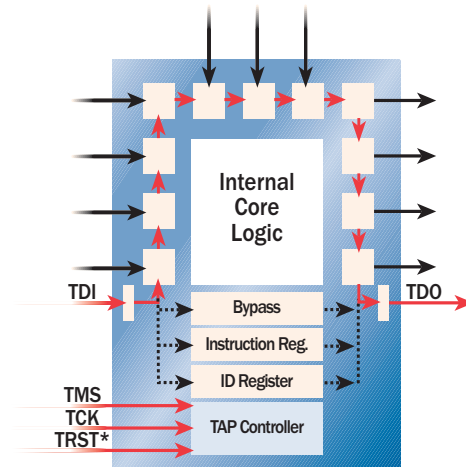

IEEE 1149.1 Device Architecture

In normal operation, a scan-compatible IC performs its intended function as though the boundary-scan circuits were not present. However, when testing or in-system programming is to be performed, the device's scan logic is activated. Data can then be sent to the IC and read from it using the serial interface. This data may be used to stimulate the device core, drive signals outward to the PCB, sense the input pins from the PCB, or sense the device outputs. The scan modes of operation provide the ability to test a board for manufacturing structural faults and to perform in-system device programming—all via the standard JTAG TAP.

The result is a tremendous reduction in the number of test points needed on the board. This translates directly into big savings: simpler board layouts, less costly test fixtures, reduced time on the in-circuit tester, increased use of standard interfaces, and faster time-to-market.

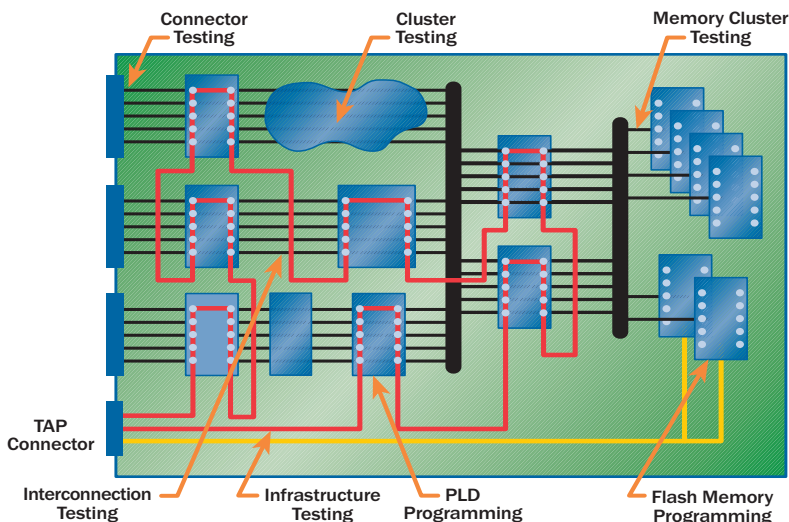

Applications of Boundary-Scan

On the programming side, boundary-scan allows configuring almost all types of CPLDs and flash memories, regardless of size or package type, on the board, after PCB assembly.

You'll realize substantial savings by reducing device handling, decreasing the burden of inventories of pre-programmed parts, and integrating the programming steps into the board production line.

Production Systems for Test and In-System Programming

Applications created on any of the Test or Programming Development Packages run seamlessly in your production systems. We support a broad range of production environments, from a stand-alone PC- or workstation-based process for test and programming, to full integration into your production line—an architecture in which boundary-scan operations take place within another process step, such as functional test.

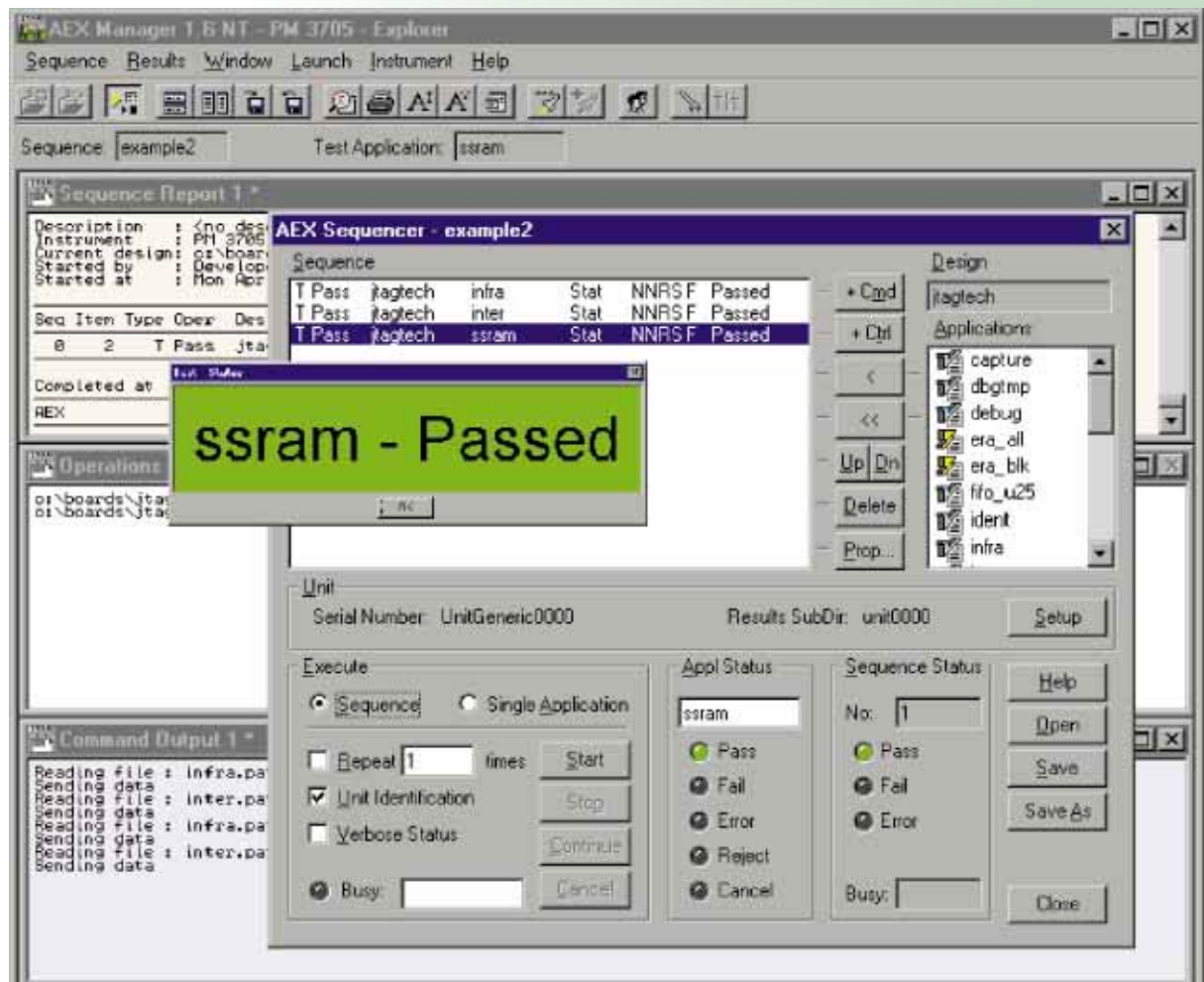

GUI of Stand-Alone Production Package

Production Packages	Windows GUI (16/32 bits)	Command Line (16/32 bits)	Dynamic Link Libraries (32 bits)	Multiple Authorization Levels	Link to Databases	Network DDE Link	LabView Drivers	LabWindows Drivers	System-Level Support	Script Creation & Execution	Pin-Level Diagnostics
Stand-Alone	✓	✓	✓	✓				✓	✓	Opt.	
Client/Server	✓					✓			✓	✓	Opt.
Production Integration		✓	✓				Opt.	Opt.	✓	Opt.	Opt.

Stand-Alone Production Package



The Stand-Alone Production Package provides all of the power of our test and programming systems, with a minimum of architectural complexity. This package turns a PC into a complete boundary-scan test and programming station. After loading the appropriate modules from your development system, you'll use the graphical application execution interface to define the sequence of operations that you need, activated by a single button push, if you wish.

We provide multiple authorization levels of system access for operators (test execution only), technicians (test flow modifications), and test engineers (test program changes). Production personnel benefit from having quick and easy controls, along with execution reports summarizing the operations. Also, the Stand-Alone Package provides an easy way to report results to your existing quality management system, such as GenRad's TRACS.

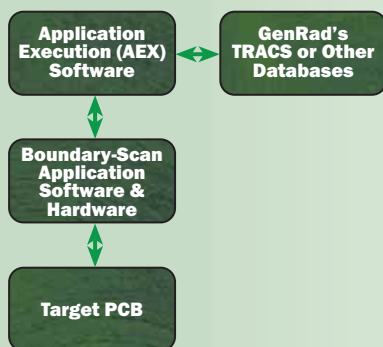

Stand-Alone Boundary-Scan System

DDE-Based Client/Server Production Package



With the Client/Server Package, you can control the boundary-scan software and hardware from your process control system, either within a single computer or across a network. The user-defined client controls the server software via DDE links to invoke the boundary-scan functions of the system. Using the client/server concept, you will be able to create an interface with your existing "Company Standard" instrument control software, adding the new boundary-scan applications as necessary.

A typical application is a production line operating remotely from a central control facility. The DDE-based Client/Server Package is also appropriate with a large number of production lines operating in parallel, facilitating large-scale gang programming through the use of more than one boundary-scan controller.

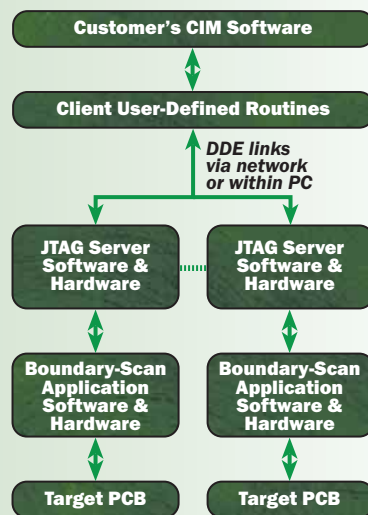

Client/Server for CIM (Computer Integrated Manufacturing) Operations

Production Integration Packages



Perhaps you've already created a user interface for other test and measurement applications. With our Production Integration Package, you'll be able to integrate boundary-scan test and programming within your existing environment. We offer a complete set of 32-bit DLLs to support integration on your Windows-based custom environment. Alternatively, we provide specific integration kits to integrate boundary-scan into industry-standard systems such as National Instruments LabWindows/CVI or LabView.

You may also use one of these Packages to integrate boundary-scan test and programming within your in-circuit tester, in a manufacturing defect analyzer, within your flying prober, or at functional test. You benefit from reduced board handling and the use of an interface that is already familiar to your operations personnel.

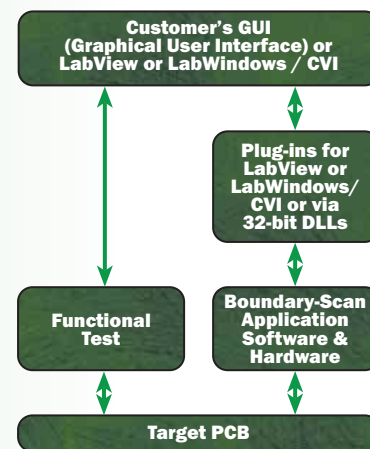

JTAG Applications Integrated in Customer's Environment

Boundary-Scan Hardware

Whether you're using boundary-scan for test, in-system programming, or both, you have a broad choice of controllers to drive your target system—all designed to meet production-level standards for reliability and ruggedness. You'll choose from three classes of performance, depending on your application and throughput requirements.

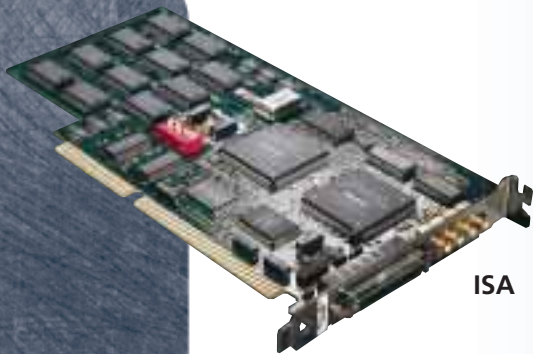

ISA

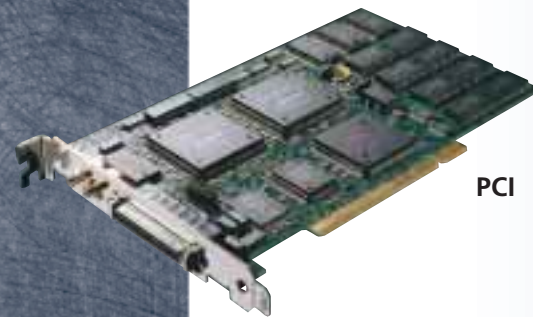

PCI



USB



VXI

DataBlaster

DataBlaster, our highest performance controller, is available in several different form factors:

- PC plug-in card (ISA or PCI)
- USB module
- C-size VXI format

Because of DataBlaster's sustained high-speed clock (25 MHz), large on-board image memory, and data-compression techniques, this controller sustains an exceptionally high data throughput. As a result, flash programming, which requires a large number of scan operations, can be performed rapidly with DataBlaster, often at the inherent capability of the flash memory itself.

DataBlaster also provides other important throughput-accelerators:

- AutoWrite (patent pending) which effectively reduces the flash programming time by a factor of two or three, compared with conventional boundary-scan methods
- Four-channel operation, allowing flash memory programming to take place on up to four target boards in parallel (gang programming).

DataBlaster includes an actively terminated POD for maintaining excellent signal integrity at the target. The POD is connected via a cable to the controller and is available in a self-contained enclosure or as a printed circuit card for easy integration into your fixtures. Connection from the POD to the target unit(s) is via up to 4 TAP cables.

DataBlasterLite

This controller is also available in ISA, PCI, USB, and VXI formats and boasts many of the same architectural features as DataBlaster, including a sustained 25MHz clock rate. Therefore, it is capable of the same high performance for test and PLD programming applications.

DataBlasterLite includes the AutoWrite feature, but because it lacks the other specific flash memory programming enhancements found in DataBlaster, it is suitable for moderately demanding flash programming applications. Of course, DataBlasterLite meets our high product standards including the actively terminated POD, in the same form factors as the DataBlaster POD, to assure signal integrity for up to four boundary-scan chains.

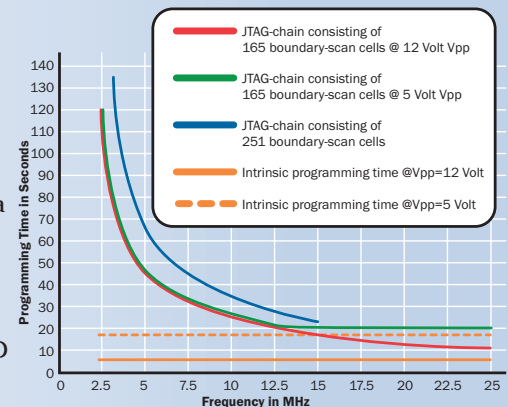

Programming times of Intel 28F016 16 Mb flash memory at various shift frequencies

Boundary-Scan Controllers	Sustained Clock Speed	Number of TAPs	Interface Types	AutoWrite™	Image Memory	Support for Gang Programming	Data Compression	Active Termination (POD)	Industrial POD
Explorer	≈100 kHz	2	Parallel Port	Opt.					
DataBlasterLite	25 MHz	4	ISA/PCI/VXI/USB	✓		✓	✓	Opt.	
DataBlaster	25 MHz	4	ISA/PCI/VXI/USB	✓	✓	✓	✓	Opt.	✓

Explorer

Explorer operates on the parallel port PC interface, allowing it to be used in all PC environments including laptops. Due to the modest speed of the parallel port, Explorer is best suited for test and PLD programming. Flash programming on Explorer is practical only if the application requires a small number of bytes or words to be programmed. This controller supports two TAP ports allowing two boundary-scan chains to be driven and observed simultaneously. Explorer connects to the PC via a standard printer cable and to the target board via one or two TAP cables.

Parallel I/O Scan Modules

We offer a family of modules to give you complete boundary-scan access to portions of the board that would otherwise be inaccessible to boundary-scan techniques. For example, board-edge connectors and cluster logic can be driven and sensed, thereby raising your board's fault coverage considerably.

Our Digital I/O Scan (DIOS) module is a stand-alone unit that drives and senses up to 64 channels per module. Up to ten DIOS modules can be operated in parallel, providing boundary-scan access to up to 640 test points.

The Extended I/O Scan (XIOS512) system consists of a chassis supporting up to four DIMM modules, each of which provides access to 128 channels. Alternatively, the DIMM modules are available without the XIOS chassis. In this case you can mount the DIMM modules directly on your in-system test fixture or target board, allowing you complete flexibility in implementing boundary-scan for your application.



PODs



Explorer



DIOS Module



Extended I/O DIMM



Interconnection Cables

Services from JTAG Technologies

To assist you in applying boundary-scan and realizing its significant benefits, JTAG Technologies offers a full menu of services and support. Our expert support team can tailor services to your needs in the following areas:

- Boundary-scan tutorials
- System installation
- Training for developers and production personnel
- Testability reviews
- In-system programmability reviews
- Design and process consultation
- Turn-key test development and programming file development
- On-site product/application support
- And, other areas according to your needs

Unlock Boundary-Scan and Put It to Work for You

The potential benefits of JTAG Technologies' boundary-scan products to your operation are significant, with compelling savings in time and money.

Reduced time-to-market

Faster prototype debugging and faster production ramp-up. Engineers' factory-support effort is reduced.

Reduced capital investment

More efficient use of conventional ATE using much less expensive boundary-scan equipment, simplified fixtures, and system commonality for test and programming.

Automated creation of test vectors and IC programming files

Speed the transition from design to factory with JTAG Technologies' advanced program generation products and integration with existing EDA tools.

Structured approach

Tools for development and manufacturing are based on an established standard, IEEE 1149.1, avoiding specialized ad-hoc methods.

Rapid resolution of manufacturing faults

Pin-level fault diagnosis is quick and easy with boundary-scan. Access problems are resolved even with surface-mount BGA and chip-scale packages.

Eliminate inventory and handling of pre-programmed ICs

Fewer process steps, avoids damage to sensitive devices, improves reliability, supports just-in-time programming, eliminates IC sockets.

No back-driving of IC outputs

Avoids potential damage to unit-under-test.

Commonality of method for test and programming throughout the product life cycle

Reduced learning time, improved inter-department process flow within R&D, production, and service. Improved feedback for corrective action.

JTAG Technologies and our authorized dealers are available worldwide to support your boundary-scan test and programming applications.

For the latest in product information, useful application tips, and the name of the dealer nearest you, please find us on the Web at www.jtag.com

JTAG Technologies B. V.

(Headquarters)

Phone: +31 40 295 08 70

Fax: +31 40 246 84 71

www.jtag.com

Email: info@jtag.nl

UK Sales Office

Phone: 01234 27 22 26

Fax: 01234 27 18 71

US Sales Office

Phone: (Toll-free)

877-FOR-JTAG (367-5824)

Fax: 410-604-2109

JTAG
Technologies B.V.